

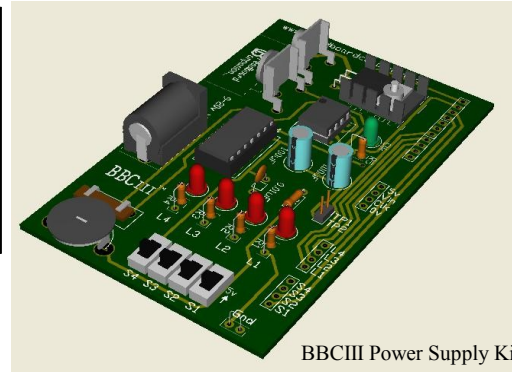

www.breadboardcompanion.com



BBCIII Power Supply Kit

Theoretical Basics

The Breadboard Companion™ power supply kit (BBCIII, or BBCJr) can be used as a tool for learning about the basics of electrical theory. Many introductory classes on electrical theory will discuss voltage, current, resistance, and capacitance. Listed below are just a few ways in which this power supply kit incorporates and applies basic electrical concepts. For the following, refer to the attached schematic.

1. Resistance and Current flow:

You might notice that there is a 1 kΩ resistor preceding every LED (light emitting diode). This is no accident. Resistors slow down the *current* (the amount of charge passing a given point in a given amount of time) along a particular path. This means that there is less current going through the LEDs than there would be if the resistors were not there. We call these *current-limiting* resistors. It is current—not voltage—that is dangerous, both to humans and to electronic components. These LEDs would not last long without the resistors, but not all LEDs are the same. Some LEDs can handle a higher current than others and though it may seem that it would be better to have a "tough" LED, it turns out that a "delicate" LED can be very useful.



Like water in a pipe, current can flow down any path that is provided, but the current—like most of us—prefers to take the *path of least resistance*. This means that most of the current will go where the least amount of resistance is. When given a choice between two paths, the current will divide up inversely proportional to the resistance. If we put a circuit in parallel with our LEDs, we will be able to drive it with more current (figure 1.1) than if our 1 kΩ resistors were not there. Since many components require a minimum amount of current to operate, this extra resistance allows us to put a larger circuit in parallel with our LEDs then we would otherwise be able to do. However, if our LEDs were "tough" and did not need a lot of resistance, then most of the current would go to our LED and we would be less likely to drive another circuit in parallel with it (figure 1.2).

Troubleshooting tip: If a circuit isn't working and the LEDs are in parallel with other components/chips. It is possible that there is not enough current to drive the other components/chips. Try disconnecting the LEDs from the circuit and see if it works.

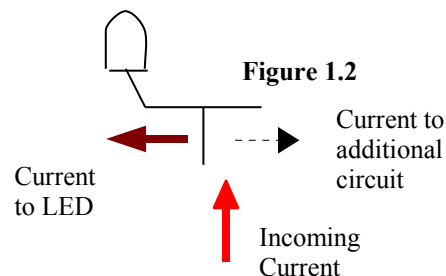
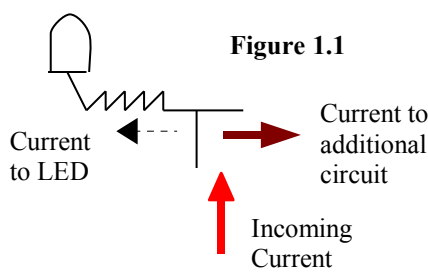

2. Capacitors and Voltage Spikes:

Though we can't usually see it, voltage sources have erratic nuances, spikes and disturbances which are often called *noise*. If we are designing a circuit that is not dependent on voltage transitions, then these spikes will not effect anything significantly. Most *combinational logic* circuits are only dependent on whether something is high or low, but not on whether it is changing from low to high or vice versa. For this reason, combinational logic circuits are not affected much by those erratic, invisible nuances. However, if we are designing a *sequential logic* circuit, in which the output states are continually changing, then we need to deal with the disturbing noise. Sequential circuits are designed so that the outputs are affected by a clock pulse that triggers the circuit. This triggering mechanism activates the circuit when it changes from low to high or vice versa. In either case, our states will change too often if we have unwanted spikes.

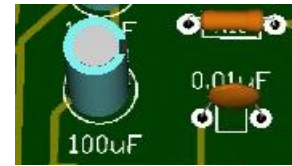

To counter for these spikes, we insert capacitors. Capacitors are like sponges for electrical charge. Like our hair when we rub it with a balloon, capacitors store a charge. Capacitors can then be used to store and release charge when needed; it can be used as a sort of electrical putty, ready to "fill in the gaps" of our spikes. However, we have different types of spikes and different capacitors are needed for each.

Though larger capacitors can store more of a charge, it takes them longer to "fill up" and to "release". This makes them effective at filling in *high amplitude*, but *low frequency* spikes (Figure 2.1). This means that the spikes are large but spaced farther apart, which gives the capacitor time to recharge. Smaller capacitors, however, can charge and discharge considerably quicker. Though they are limited in the amount of charge they have, they can dispose of it quickly, refill quickly and be ready to go in a moment's notice. This makes the smaller capacitors effective at filling in *low amplitude*, *high frequency* spikes (Figure 2.2).

If you look at the schematic, you will notice that C1 is a very small capacitor (0.01 μF) and it is connected directly with 5v and Gnd. This takes care of the low amplitude, high frequency spikes that enter the 555 chip. Looking again at the schematic, you will notice that C2 is a much larger capacitor (100 μF) and that it is also connected directly with 5v and Gnd. Unlike the small capacitor, this one should take care of any large disturbances in your circuit and should be placed close to the initial power supply.

Troubleshooting Tip: If you are designing a sequential logic circuit and the clock pulse appears to be erratic, try using a 0.01 μF capacitor to connect the power and ground of each IC (integrated circuit) chip you are using in your circuit. This should protect each chip from the small disturbances that get past the "big" capacitor.

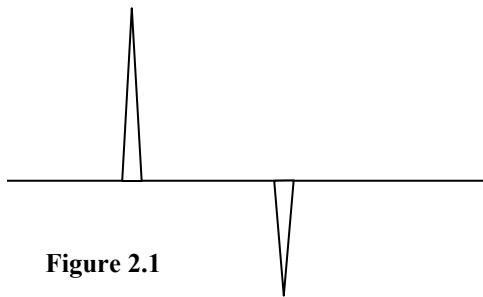
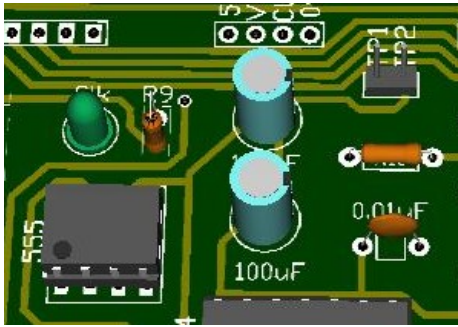

Figure 2.1



Figure 2.2

3. The 555 Timer and the RC Time Constant:



If you look at the schematic, you will notice a chip called the NE555N. This is a *555 Timer* and it is used to create a *square wave*. This square wave is what we will use for a clock pulse when we are ready to design *sequential logic* circuits. The BBCIII power supply kit is equipped with two test points, TP1 and TP2. If you hook an *oscilloscope* (see tip below) on to TP1, you will see what this square wave looks like (Figure 3.1 is a rough picture of what is happening). Our particular square wave oscillates between 0 and 5 volts which, because it spends very little time between the two voltages, makes it look like it has square corners on it. Theoretically, a square wave "jumps" from 0v to 5v without ever hitting anything in-between. If you spin the dial on the *potentiometer*—which is nothing more than a resistor that can change its value from 0 to 10 k Ω —you will notice that the *frequency* of the square wave changes.

Though we will reserve a thorough examination of the 555 Timer until section #4, it is important for us to understand that its oscillation rate is based on the charging and discharging of a capacitor. If we want a regular and consistent frequency on our square wave, then we must base it on something that is very regular in of itself. The amount of time it takes for a capacitor to charge is always based on the size of the capacitor and the amount of resistance along the charge path. If you think about it, this makes sense. If there is more resistance in a path, then the current will be slower and the charge will take longer to fill up the capacitor. Similarly, if the capacitor is larger, then it will take longer to "fill it up". This relationship is called the *RC Time Constant*, and it says that a capacitor will charge to 63% capacity when the time (in seconds) equals the product of the resistance and the capacitance. The time it takes to charge is exponential (Figure 3.2), and therefore the rate at which it is charging is continually decreasing. It takes a capacitor approximately $5 RC$ seconds to charge completely. The discharge of a capacitor works the same (Figure 3.3).



Figure 3.1

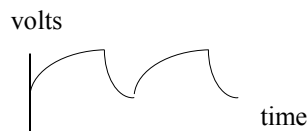

Figure 3.4

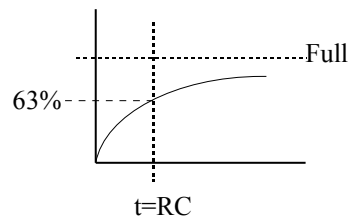

Figure 3.2

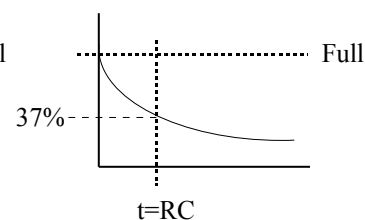

Figure 3.3

Our 555 Timer is dependent on the charging and discharging of capacitor C3 and if you hook an oscilloscope up to TP2, you will see exactly what is happening in the capacitor (Figure 3.4 is a rough picture). You will notice that it takes longer to charge than to discharge. Why is that? If you look at the schematic, you will see that the C3 capacitor charges along a path from VCC that includes two resistors, R6 and the potentiometer. However, the discharge path (pin 7 of 555) only goes through the potentiometer. This means that there will *always* be more resistance in the charge path than the discharge path and that it will always take longer for the capacitor to charge than to discharge. Since the potentiometer is in line with both the charge and discharge path, adjusting it affects the amount of time it takes for the capacitor to charge *and* discharge and thus affects the frequency of the square wave.

Oscilloscope Tip: Oscilloscopes work best at high frequencies. It will be difficult to get a good signal from the low frequencies produced by the BBCIII power supply kit. Adjust the clock pulse to their highest frequency and try using time intervals of 10-20 ms for TP1 and 50 ms for TP2. If you are still having trouble getting a signal, try hooking an oscilloscope up to the 555 Companion, as it operates at higher frequencies.

4. 555 Timer guts and the transistor:

The intent of this last section is to briefly describe what is inside of a 555 Timer and superficially explain how it works. Examining Figure 4.1, we can see that the 555 timer is essentially made up of three resistors, two *comparators* (triangles), a *latch*, and a *transistor* (T1).

- As we learned from before, resistors "resist" the flow of electricity, thus slowing down the current and proportionally dropping the voltage.
- Comparators get their name because they compare two voltages: when the (+) input voltage exceeds the (-), it outputs a *high*, otherwise a *low*.
- A latch is a device that holds a value into memory. Like an alarm, it can be set and reset. When a latch is set, "Q" will go *high* and stay *high* until the latch is reset, then "Q" will go *low* and stay *low* until it is set again.
- A transistor is like an electrical switch (Figure 4.2). When the base (B) is *high*, the "switch" is essentially closed and completes the circuit between the collector (C) and the emitter (E). When the base is *low*, the "switch" is open and the current cannot flow through the transistor.

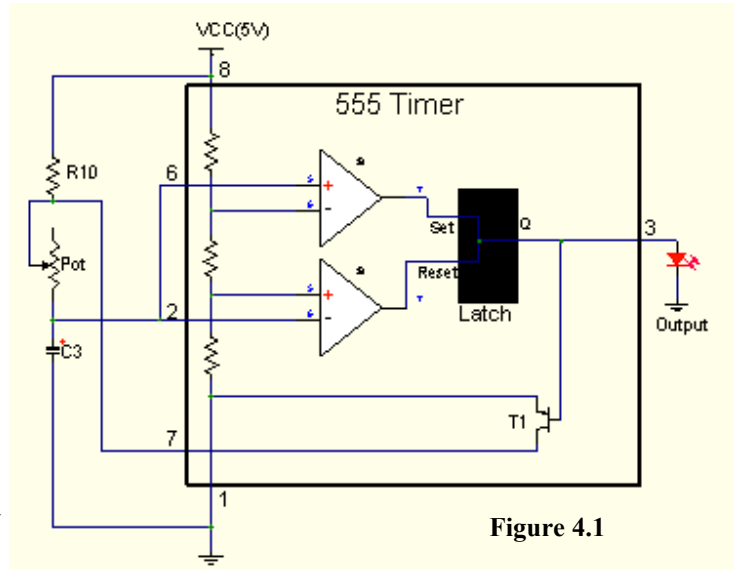

Figure 4.1

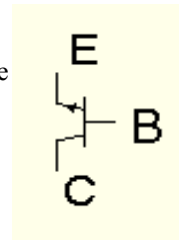

Figure 4.2

As you recall, on any one path between 5v and 0v, 5 volts will be dropped proportionally between the resistance along that path. Between VCC (5v) and Gnd (0v), we have three resistors of equal value. Since the comparators are connected between the resistors, one comparator is using 2/3 VCC as its reference and the other comparator is using 1/3 VCC as its reference. The other ends of the comparators are both connected to our charging capacitor. This means that the comparators are activated when the capacitor is either 2/3 full or 1/3 full.

When the capacitor is charging, the "top" comparator is keeping an eye on how full it gets. When the capacitor reaches 2/3 VCC, an instantaneous cascade of events begins to occur. The comparator goes *high*, the latch is set, "Q" on the latch goes *high*, the base of the transistor likewise goes *high* and the "switch" closes, allowing the current to pass from the emitter to the collector. Since the collector is connected to our 2/3 charged capacitor and the emitter is connected directly to ground, the capacitor now has a discharge path through the potentiometer. The capacitor begins to discharge.

Now the "bottom" comparator is keeping an eye on how empty it gets. When it reaches 1/3 VCC, another similar cascade of events takes place. The "bottom" comparator goes *high*, the latch is reset, "Q" goes *low*, the base of the transistor is no longer activated and the discharge path is disconnected. With no discharge path, the capacitor begins charging again. The comparators control the charge and discharge of the capacitor. Since the capacitor will always charge and discharge at a constant rate (see section #3), the square wave will maintain a constant frequency of high and low.